

CXC10

Tool Changers designed to minimize downtime

Applied Robotics offers a full line of robotic tool changers designed to minimize assembly line downtime and increase productivity.

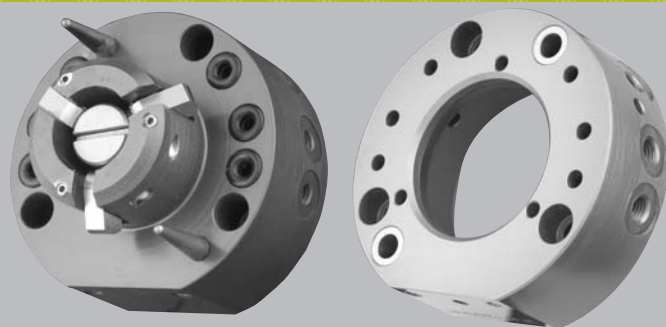

Features and Benefits

- When you're doing batchmode manufacturing, you can reduce line changeovers from hours to seconds.
- When you're maintaining or repairing tools you can have a second identical tool available, that won't need recalibration.
- Now your robot can perform multiple tasks with a simple tool change.
- Unique triple-cam latching mechanism prevents deflection from heavier payloads
- High strength to weight ratio
- Patented contacts in electrical block are spring-loaded to reduce wear from repeated coupling/uncoupling

Applications

- Light to medium assembly
- SMT work cells
- Material removal
- Pick and place
- Material Handling

Not exactly what your application requires? Applied Robotics can design a solution that meets your particular application needs.

SPECIFICATIONS

Moment Resistance M_x & M_y	29 N-m nominal	260 in -lb nominal
Torque Resistance M_z	34 N-m	303 in-lb
Maximum Axial Tensile Force (no damage if exceeded)	1863 N @ 0 bar couple port input pressure	418 lb @ 0 psi couple port input pressure
Position Repeatability X & Y	+/- 0.025 mm	+/- 0.001 in
Position Repeatability Z	+/- 0.025 mm	+/- 0.001 in
Center of Mass (from robot faceplate)	29 mm	1.14 in
Weight (with robot and tool adaptor plate)	.40 kg	0.91 lb

ROBOT - TO -TOOL UTILITIES

User Electrical Lines (available with or without cables)	18 @ 5 amps each
User Pneumatic Ports	(6) M5
Pressure range	4 - 8.5 bar 56 - 123 psi

ACTUATION

Couple & Uncouple Ports	(2) M5
Nominal Working Pressure Range	6 bar +/- 1 87 psi +/- 15

Note: Specifications provided are maximum recommended limits under static conditions. For correct product sizing, consideration must be given to all applicable dynamic forces, including manipulator inertia, tooling configuration and external process forces.

Note: For correct product sizing, please contact our Tech Support staff at tech-support@arobotics.com or via telephone at (800)309-3475 in NY or in MI at (248)358-3677.

Engineering Data

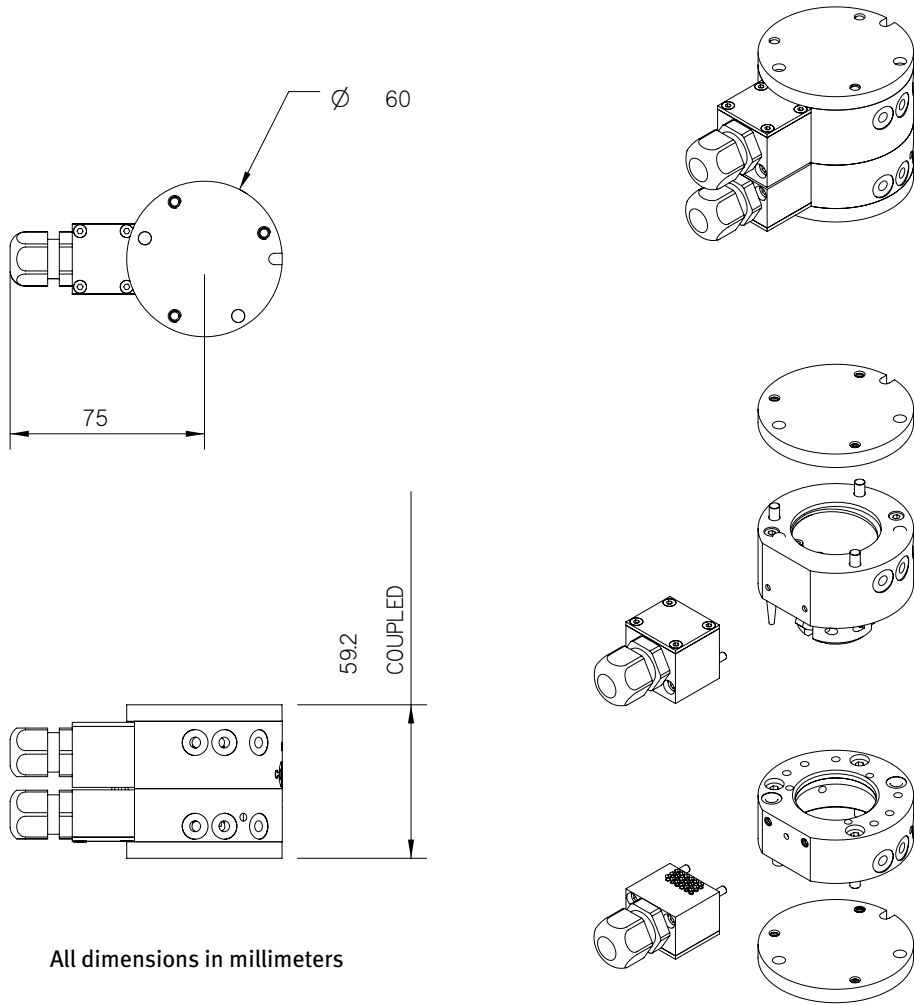

All dimensions in millimeters

Moment Charts (Moment/Deflection curve shown represents the orientation that yields maximum deflection)

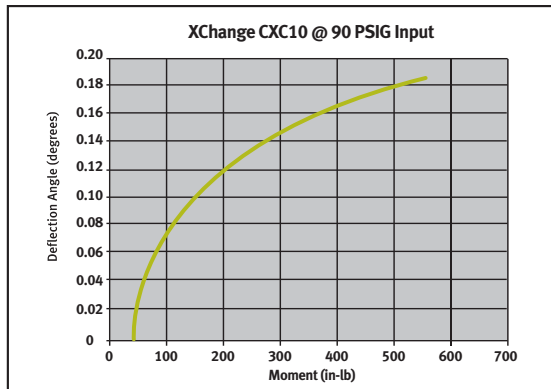
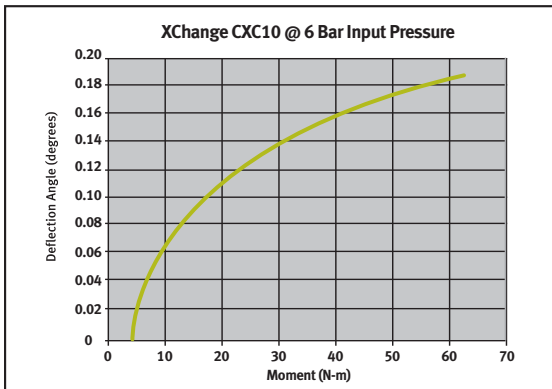

648 Saratoga Road
 Glenville, NY 12302 USA
 518 384 1000 tel
 518 384 1200 fax

29193 Northwestern Hwy. #509
 Southfield, MI 48034 USA
 248 358 3677 tel
 248 358 2654 fax

www.arobotics.com

