



AA- Motorized 3 Axis Alignment Stage

Micro Motion Technology

Micro Motion Technology Co., Ltd. (MMT) is the leading manufacturer and distributor of high precision positioning tables and precision components used for development and application of the advanced research and industrial applications.

AA Series motorized 3 axis alignment stage has very low profile and enables the user to create compact alignment system. Three different sizes are provided for wide range of applications needs.



AA-300-3S



AA-400-3S

Features

- Fine X-Y-T 3-axis alignment stage for inspection system (Hollow hole is optional)
- Travel range : ± 10 mm / ± 10 mm / $\pm 15^\circ$
- 5 μ m accuracy
- Low profile stage - 3-axis are on the same plane
- High stiffness cross roller guide stage
- Vacuum environment compatible is optional

Applications

- Precision processing and inspection systems of Semiconductor, LCD, FPD, PCB, etc.

SPECIFICATION	AA-200-3S	AA-300-3S	AA-400-3S
Table Dimension (mm)	200x200	300x300	400x400
Travel Range (mm)	$\pm 5/\pm 5/\pm 2.5^\circ$	$\pm 5/\pm 5/\pm 2.5^\circ$	$\pm 10/\pm 10/\pm 2.5^\circ$
Travel Guide	B/S Ø8, L1, Cross Roller	B/S Ø10, L2, Cross Roller	B/S Ø14, L2, Cross Roller
Resolution (mm)	0.002/Pulse(Full Step)	0.004/Pulse(Full Step)	
Maximum Speed	20mm/sec[5kHz]	40mm/sec[5kHz]	40mm/sec[5kHz]
Accuracy	5 μ m	5 μ m	5 μ m
Uni-Repeatability	$\pm 1\mu$ m	$\pm 1.5\mu$ m	$\pm 1.5\mu$ m
Bi-Repeatability	$\pm 2\mu$ m	$\pm 3\mu$ m	$\pm 3\mu$ m
Parallelism (mm)	0.03	0.03	0.04
Running Parallelism (mm)	0.02	0.02	0.03
Straightness (mm)	0.01	0.01	0.015
Load Capacity (kg)	30	50	80
Material	Aluminum (Option. SUS)		
Weight (kg)	15	20	40
Motor Model	PK-545-NB (5P STEP)		
Drive Model	DFC5107-P(DC 24V)		
Sensor	1 Home Sensor, 2 Limit Sensor		

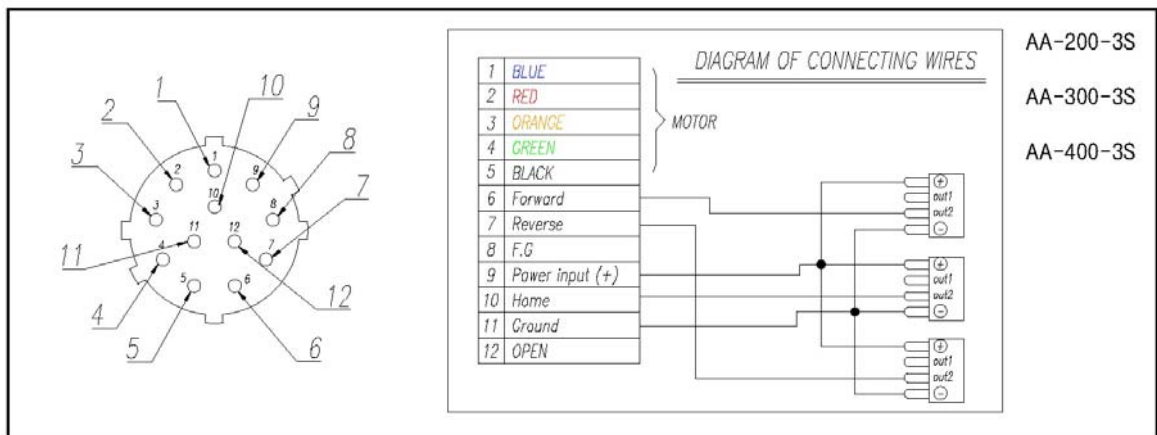

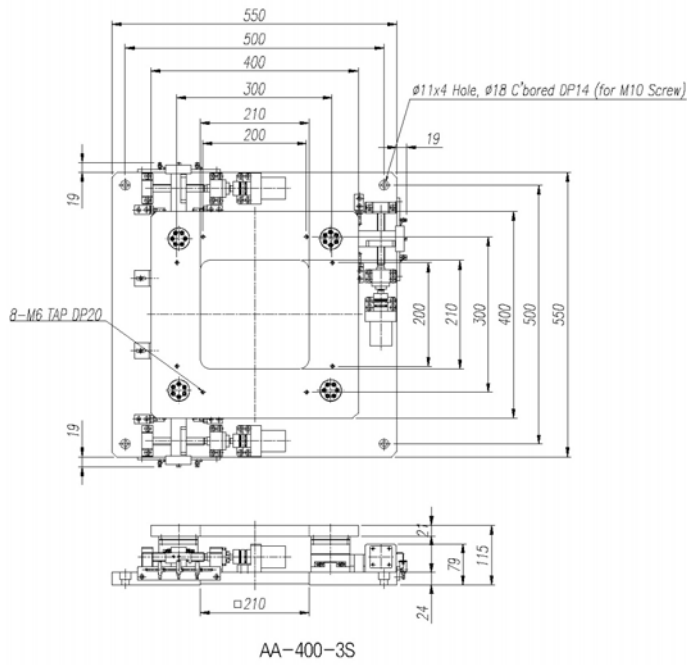
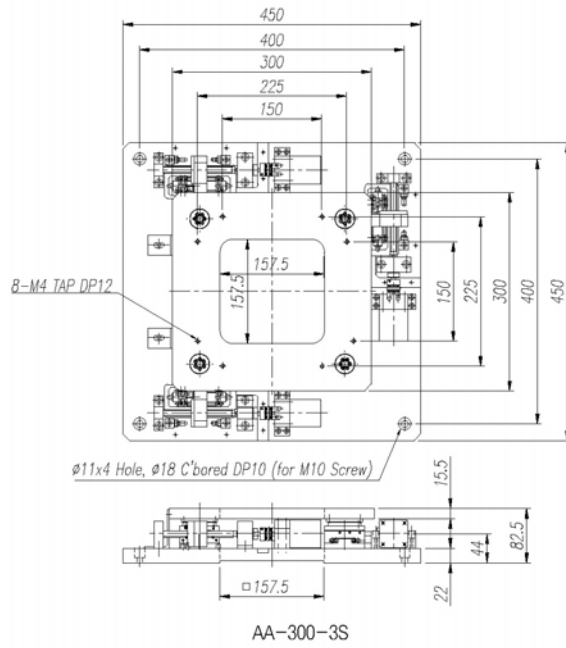
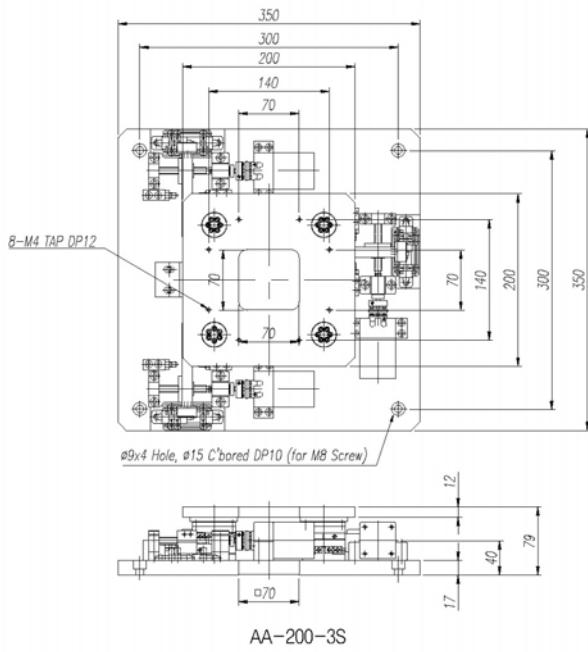

MOTORIZED ALIGNMENT STAGE

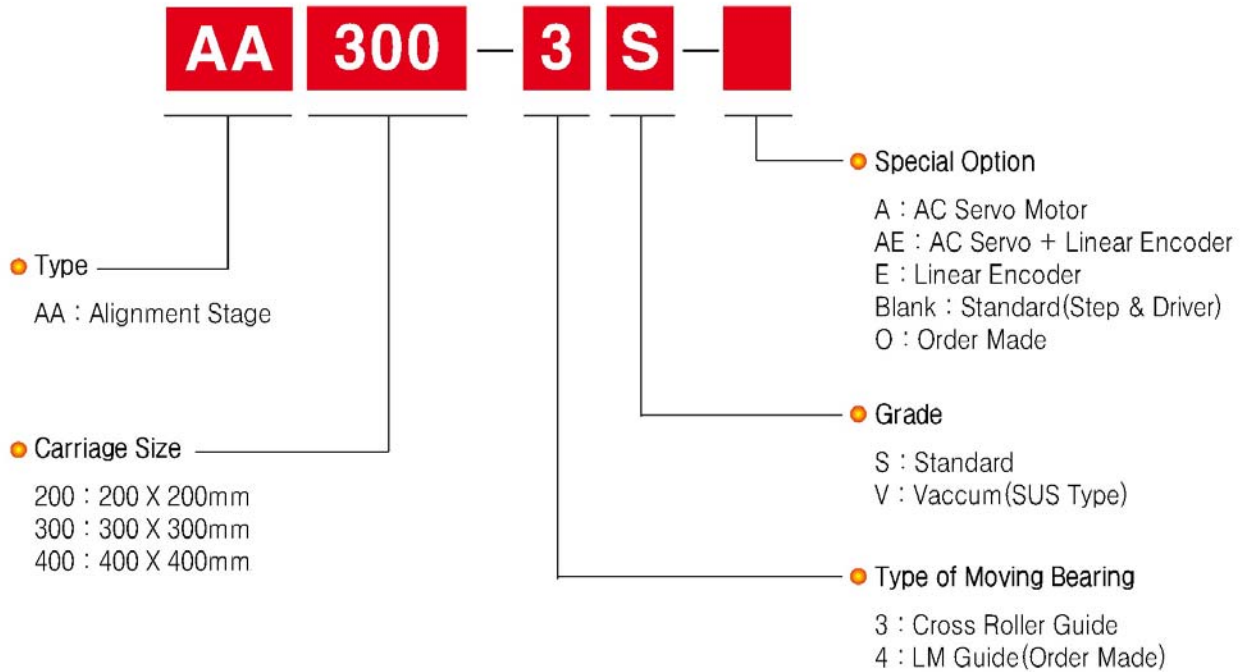

► **Note :** All Products are able to be Changed by Custmer Order
MMT can be Satisfied with custmer request