

Innovation Matrix

Product Catalog

Introducing



Bridging the Pacific with Automation Technology

Adept Cobra™ i800

90566-000



The Adept Cobra i800 is an extended reach version of the Adept Cobra i600 robot, offering the same payload and performance at an affordable price. It is designed for mechanical assembly, material

handling, packaging, machine tending, screwdriving, and many other operations requiring fast and precise automation.

Robot Specifications

Reach	800 mm
Payload	2 kg (rated) 5.5 kg (max)
Joint 4 inertia (max)	450 kg-cm ²
Downward Push Force	30 kgf
Adept Cycle	
Burst Mode	0.54 sec (2 kg)
Sustained	0.54 sec (2 kg)
Joint Range	
Joint 1	±105°
Joint 2	±157.5°
Joint 3	210 mm
Joint 4	±360°
Joint Speeds	
Joint 1	386 °/sec
Joint 2	720 °/sec
Joint 3	1,100 mm/sec
Joint 4	1,200 °/sec
Repeatability	
XY	±0.017 mm
Z	±0.003 mm
Theta	±0.019°
Pass-Through User Connections	
Electrical	24 (12 twisted pairs)
Pneumatic	6 mm (x2) 4 mm (x3)
DeviceNet	
Digital I/O Channels	12 inputs 8 outputs (included)
Weight	43 kg

With no external electronics, the Adept Cobra i-series is the only line of self-contained, standalone SCARA robots. The amplifiers and motion controller are built into the robot, making the Adept Cobra i800 one of the easiest robots to design into workcells where space is critical.

Installation is easy. Simply supply power, attach the emergency stop, and plug in digital I/O cables to interface to other peripherals. Add tooling and vacuum lines, then connect a PC directly to the robot, and program the arm using the simple, yet powerful, MicroV+™ robot language. The PC can be removed for runtime.

Key Features

- No external electronics - the amplifiers and motion controller are built into the robot arm, significantly reducing the size and number of cables, which dramatically simplifies system installation
- MicroV+ real-time operating system and easy-to-use programming language

Performance

- Absolute encoders make for easy calibration
- High-resolution encoders provide high-precision and superior slow-speed following
- High-efficiency motors deliver high performance with more torque per amp
- Low-inertia harmonic drives provide maximum acceleration
- Temperature sensors on the motors and amplifiers maximize performance and reliability
- 8 kHz servo update for improved path following and control

Reliability and Maintenance

- Integrated temperature sensors monitor heat in servo motors to prevent damage
- Diagnostics display on robot enables faster troubleshooting
- Easy replacement of electronic sub-assembly reduces MTTR

Adept Cobra™ i800

System Includes:

The Adept Cobra i800 system (p/n 90566-000) includes the following:

- Adept Cobra i800 Robot with MicroV+ installed
- Front Panel with E-Stop
- Adept DeskTop 2.0 software on CD-ROM
- RS-232 Null Modem Cable
- X-PANEL Cable (for connecting E-Stop, Front Panel and MCP)
- User Documentation

User Supplied Items

User must supply the following items:

- Power to robot (see power requirements)
- External Emergency Stop
- Power enable push-button (if Adept Front Panel not used)
- Windows™-based PC (not required at run-time)

Environmental Requirements

Ambient temperature	5°C to 40°C
Humidity range (non-conducting)	5 to 90%
Altitude	Up to 2,000 m

See user's documentation for controller enclosure recommendations.

Power Requirements for Cobra i800 Robot

24VDC (+/- 10%), 120W (6A), User-Supplied
200V to 240V AC, 1-phase, 50/60Hz (10A), User Supplied

Downloads

Download CAD files from www.adept.com using the following download ID's:

Adept Cobra i800 Robot	500008
Front Panel	135905

Optional Peripherals

- T1 Pendant
- IO Blox (8 digital input & 8 digital output channels)
- Hardstop kit
- Solenoid kit

For More Information

Call for a quotation 800-226-6385. The Adept Cobra i800 robot is available by ordering part number 90566-000.

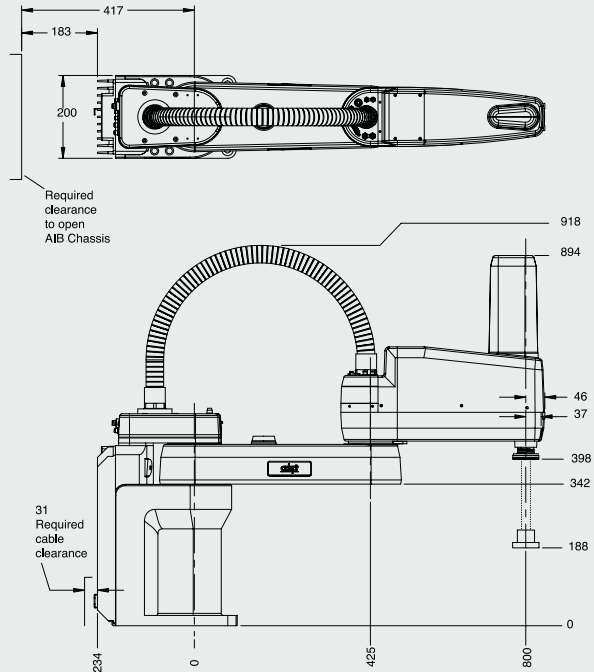

Top and Side Dimensions

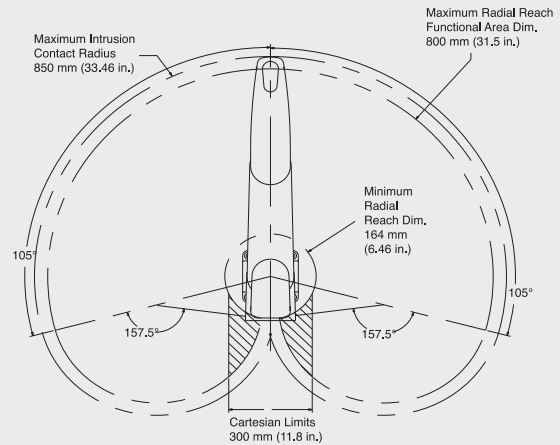

Work Envelope



Adept Technology, Inc. 3011 Triad Drive, Livermore, CA 94551
Tel: 925-245-3400 Fax: 925-960-0452 Email: info@adept.com www.adept.com

Specifications subject to change without notice.

©2005 Adept Technology, Inc. All rights reserved. Adept and the Adept logo are registered trademarks, and Adept Cobra is a trademark of Adept Technology, Inc. All other trademarks are the property of their respective holders.

www.innovation-matrix.com



Innovation Matrix, Inc.

1715 Junction Avenue, Suite B, San Jose, CA 95112 USA

TEL: 408-329-4422

FAX: 408-716-2553

sales@innovation-matrix.com

IM Japan: japan@innovation-matrix.com

IM Taiwan: taiwan@innovation-matrix.com

IM Beijing: beijing@innovation-matrix.com